

Terwin Instruments Ltd.

Winterbeck Industrial Estate, Orston Lane,
BOTTESFORD, Nottinghamshire, NG13 0AU ENGLAND
Tel: +44 (0) 1949 84 2000 Fax: +44 (0) 1949 84 2004
E-mail: info@terwin.com

TERWIN 1100 SERIES PRESSURE TRANSMITTER DATA SHEET

INSTALLATION AND CALIBRATION

The 1100 series pressure transmitters are precision instruments and it is important to follow the instructions below to avoid unnecessary damage.

HANDLING

The transmitters should be handled with great care. They should not be dropped and the diaphragm on the transducer should be prevented from coming into contact with sharp objects. Under no circumstances should the diaphragm be cleaned with a wire brush or abrasive cleaners. If the transducers require cleaning, use only a clean cloth when the transducer is hot and at around the same temperature as the material which was previously being processed. Additionally, always ensure that before removing a transducer from an extruder, the processed material is still at its working temperature. If the material being extruded has become cold, this could lead to the diaphragm being damaged when the transducer is removed. Under no circumstances must the transducer be removed from the extruder whilst under pressure.

BEFORE INSTALLATION

Always ensure that the mounting hole conforms to the required dimensions which are shown on the reverse of this leaflet, and that it is clean and entirely free of old processed material which may damage the transducers sensitive diaphragm.

INSTALLATION

TRANSDUCER SECTION

Lubricate the threads of the transducer before each installation with Dow Corning Molycote g or a similar product. Screw the transducer into the extruder and torque to 20ft-lbs. maximum - 10ft-lbs. minimum. Do not over torque as this may lead to the transducer being damaged beyond repair.

INSTALLATION

TRANSMITTER SECTION

The transmitter has been designed for wall mounting and two 6.0mm diameter holes are provided in the lid for this purpose. Always ensure that the transmitter is mounted in a position where ambient temperatures do not exceed 65°C (149°F). Connect the transmitter to the transducer in the extruder and ensure that a stabilised voltage supply of between 12 - 36vdc is connected to the transmitter via the cable assembly provided.

NOTE:

The value of the load resistor (RL) selected must be in accordance with the specifications that are detailed in our drawing No: MSD/2000/0211 (a) supplied with this sheet. This resistor is not provided with the transmitter.

Continued . . .

TRANSMITTER / TRANSDUCER CALIBRATION.
(ALL ADJUSTMENTS ARE TO BE MADE AT ZERO PRESSURE.)

After installation of the two sections as described on the previous page, proceed as follows:

1. Ensure that the pressure transducer is at working temperature and power has been applied to the transmitter section.
2. Removes the M4 crosshead screw on the transmitter housing which conceals the zero adjust potentiometer. Using a small instrument screwdriver, adjust the zero trim potentiometer to read 4.0mA D.C. or zero psi / bar etc on the pressure display instrument.
3. Remove the remaining two M4 crosshead screws that conceal the calibration switch (CAL) and the span adjustment potentiometer.
4. Using the small instrument screwdriver, press the CAL switch and with another screwdriver adjust the span potentiometer until the output signal is equivalent to 80% of the full range of the transmitter output i.e., 16.80mA D.C. or 80% of the full range on the pressure display instrument.
5. Re-check zero reading and adjust again if necessary and then repeat span adjustment as detailed in section 4 above.
6. Replace the three protective M4 crosshead screws in the zero, span and calibration positions

CAUTION: DO NOT MAKE ANY ADJUSTMENTS TO THE TRANSMITTER WHEN THERE IS PRESSURE ON THE TRANSDUCER. THIS COULD CAUSE THE PRESSURE READING TO BE LOW, RESULTING IN THE MACHINE BEING OVERPRESSURISED.

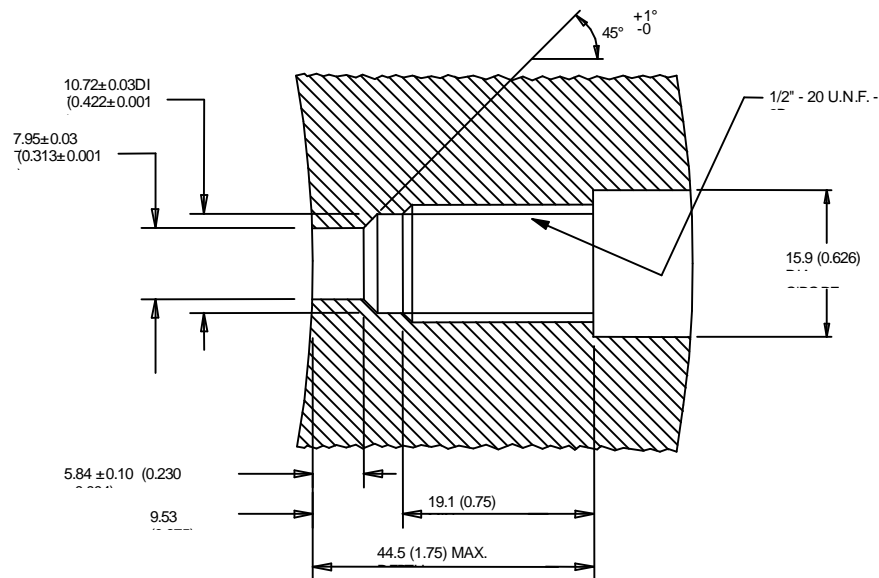

**RECOMMENDED WELL DIMENSIONS FOR 1/2 INCH 20UNF THREADED
TRANSDUCERS**

If you should have any queries with regards to the installation of our 1100 series pressure transmitters, please do not hesitate to contact our service or sales department for advice.